

CAPACITY	SYMBOL/ SERIAL NO.	CIRCUIT DIAGRAM
AC100-240V, 50/60Hz		
25W		

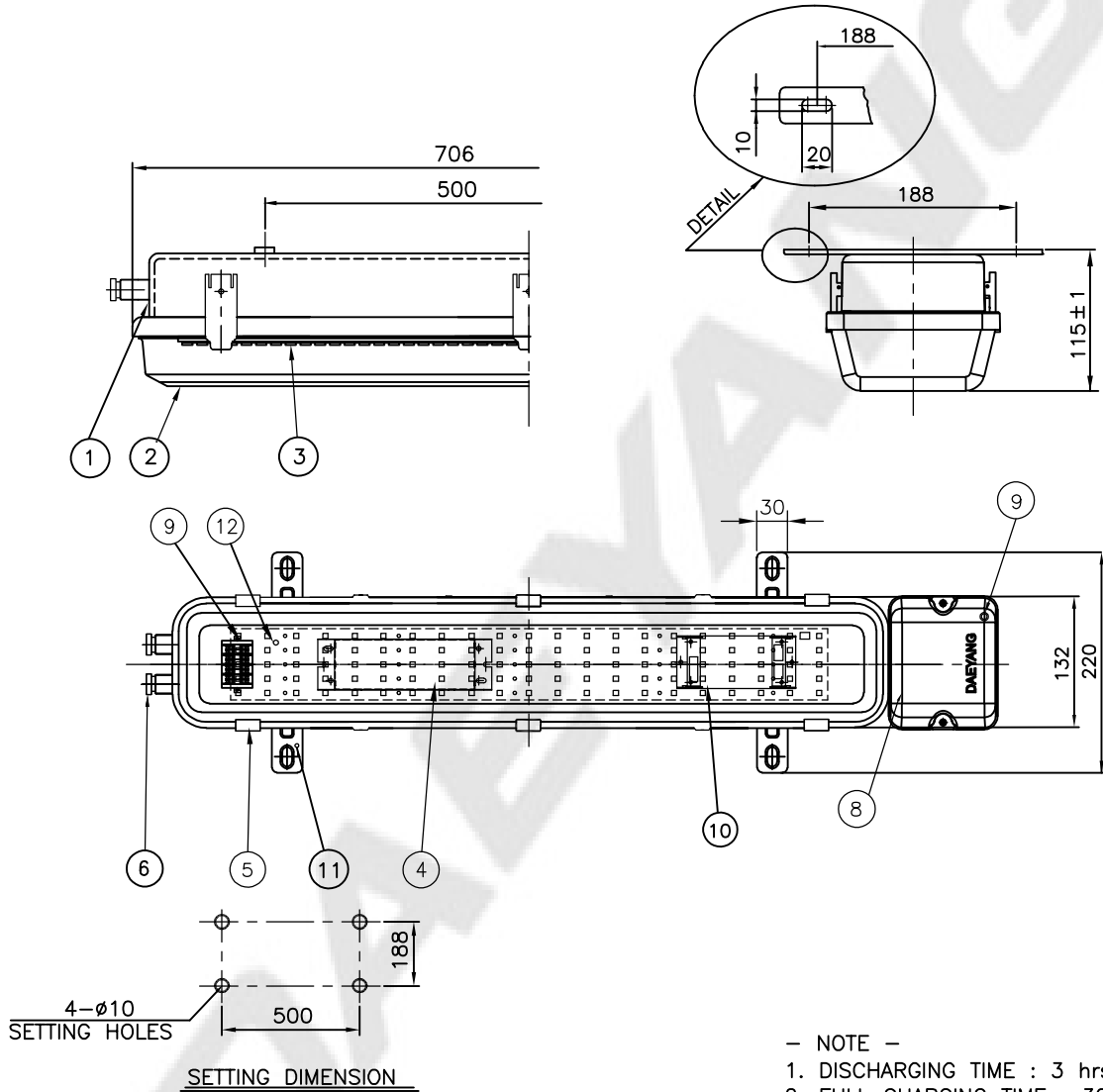

12	INSIDE EARTH BOLT	STAINLESS STEEL304	1	M4	6	CABLE GLAND	BRASS	2	ø10~ø12
11	OUTSIDE EARTH BOLT	STAINLESS STEEL304	1	M5	5	LATCH	STAINLESS STEEL316L	6	
10	EMERGENCY LED driver	-	1		4	LED driver	-	1	
9	INDICATION LAMP	-	1		3	LED module	-	1	4,000±300K
8	BATTERY CASE	-	1		2	GLOBE	POLYCAR-BONATE	1	
7	TERMINAL BLOCK	-	1	CLAMPING 5P	1	BODY	STAINLESS STEEL316L	1	
NO	NAME OF PARTS	MATERIAL	Q'TY	REMARKS	NO	NAME OF PARTS	MATERIAL	Q'TY	REMARKS

APPROVED	B. K. KIM	UNIT	MM	TITLE; LED CEILING LIGHT (SURFACE, BATTERY BACKUP TYPE) FOR MARINE USE			
CHECKED		SCALE	N/S				
DRAWING	B. I. KIM	COLOR	N-9.3				
DATE	2015.12.04	IP	66/67				
DAEYANG				MODEL NO.	LEB125WS-0550UWNM2GLw12BuQC40	WEIGHT	4.9 Kg
				DWG NO.	LO1450190	SHEET NO.	11

NO	CONTENT	DATE	REVISER	APPROVAL
△				
△				
△				

— NOTE —

* INDICATION LAMP COLOR STATUS

NO	LED		MODE
	GREEN	RED	
1	Steady	—	Full charged
2	—	Steady	Charging
3	—	—	Discharging
4	—	—	Battery fault

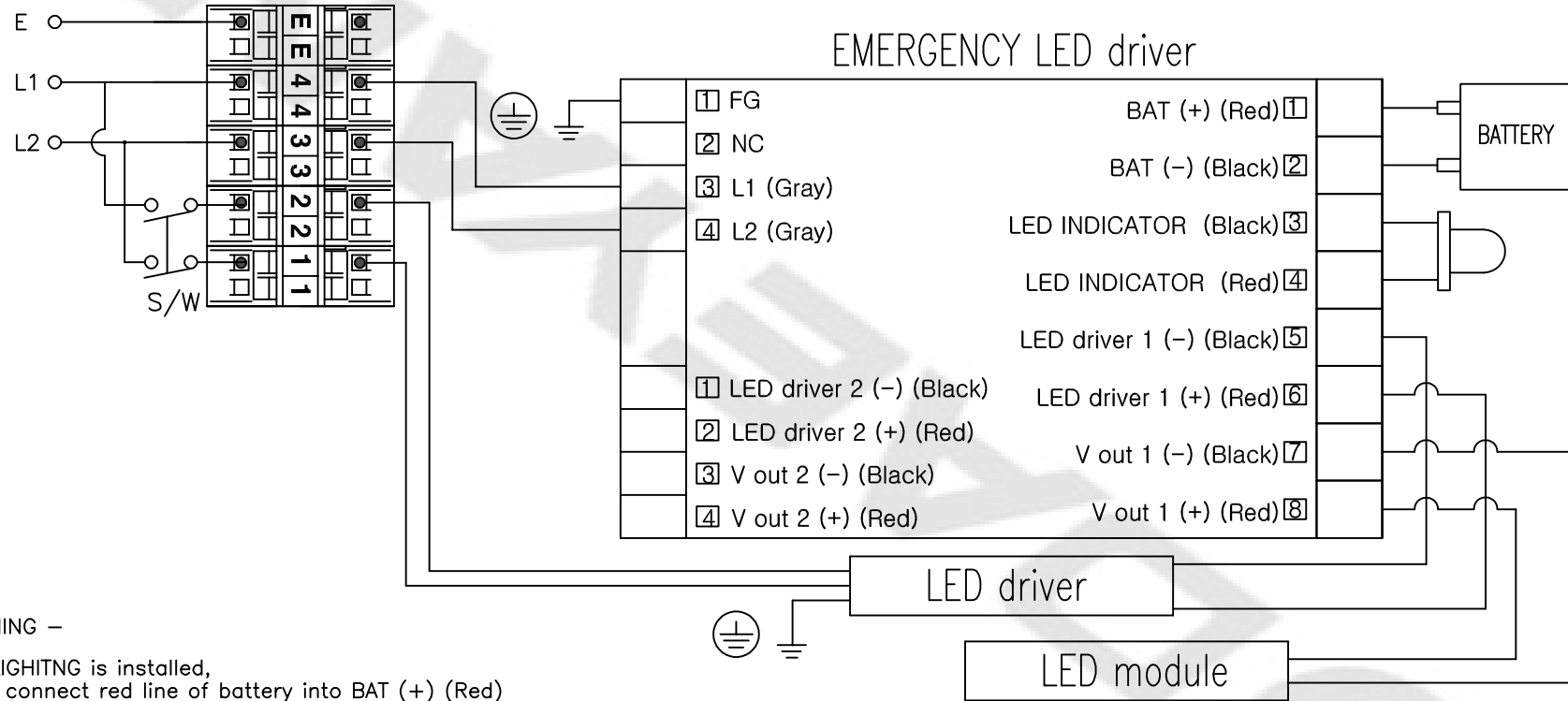

— WARNING —

1. After LIGHTING is installed, please connect red line of battery into BAT (+) (Red)
2. When the continuous power is not supplied, red line of battery into BAT (+) (Red) should be disconnected to avoid natural discharge of battery.
3. Please install switch for on/off LIGHTING.

TITLE: LEB125WS-0550UWNM2GLw17BuQC50 Connection Diagram	SCALE	N/S	UNIT	MM	NO.	REVISED
	PROJECT METHOD	⊕	WEIGHT	KG	△	
	APPROVED	B. K. KIM			△	
	CHECKED				MATERIAL	ASS'Y
	DRAWN	B. I. KIM			DWG NO.	
	DATE	2016.02.02			SHEET NO.	11-A